

DELAVAN PRECISION OIL BURNER NOZZLES

Type WDA & WDB

Pressure Atomizing Nozzles for humidifying

Spray Characteristics

- Finely atomized cone spray pattern for humidifying
- WDA has a hollow cone pattern
- WDB has a solid cone pattern
- Available spray angles - 30 , 45 , 60 , 70 , 80 and 90

Ordering Instructions

WHEN ORDERING TYPE WDA & WDB NOZZLES, be sure to specify the following :

- 1) Nozzle number per capacity chart
 - 2) Spray angle
 - 3) Material (brass with stainless steel metering parts will be furnished if material is not specified).
- Order adapters separately, see selection chart.

Materials

Nozzle bodies are available in brass or stainless steel with a stainless steel orifice disc. Distributors are stainless steel and retainers are available in brass or stainless steel. Strainers are furnished up through WDA/WDB15 (15.0 GPH @ 125 PSIG) with each nozzle.

Adapter Selection Chart

Pipe Size	Adapter P/N		Length	
	Brass	S.S.	Adapter only	Adapter plus nozzle
1/8 NPTF	28737-1	28737-2	1.375"	1.905"
1/4 NPTF	28737-3	28737-4	1.375"	1.905"
3/8 NPTM	28741-1	—	1.375"	1.905"

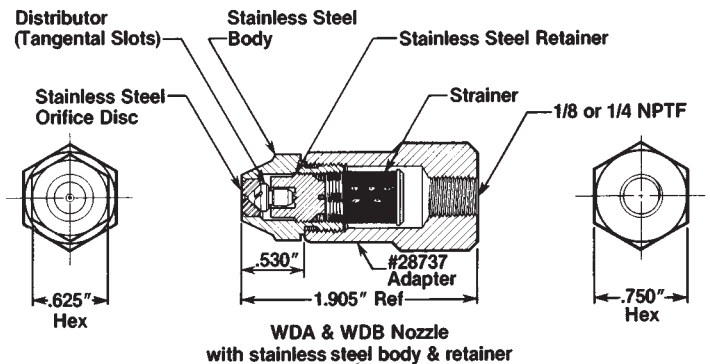

WDA-WDB CAPACITY CHART

NOZZLE NO. = CAPACITY AT 125 PSIG

NOZZLE NUMBER			App. Orif. Dia.	CAPACITY — GPH AT PSIG PRESSURE — based on water							
WDA	WDB	No.		30 PSIG	40 PSIG	75 PSIG	100 PSIG	125 PSIG	150 PSIG	300 PSIG	500 PSIG
WDA	WDB	*.50	.0083	—	—	.39	.45	.50	.55	.77	1.0
WDA	WDB	*.75	.0092	—	—	.58	.67	.75	.82	1.16	1.5
WDA	WDB	1.0	.011	—	—	.77	.89	1.00	1.10	1.55	2.0
WDA	WDB	1.5	.013	—	—	1.16	1.34	1.50	1.65	2.32	3.0
WDA	WDB	2.0	.015	—	—	1.55	1.79	2.00	2.20	3.10	4.0
WDA	WDB	2.5	.016	—	—	1.93	2.24	2.50	2.74	3.88	5.0
WDA	WDB	3.0	.018	—	—	2.32	2.68	3.00	3.30	4.65	6.0
WDA	WDB	4.0	.025	—	2.2	3.1	3.6	4.0	4.4	6.2	8.0
WDA	WDB	5.0	.025	—	2.8	3.9	4.5	5.0	5.5	7.7	10.0
WDA	WDB	6.0	.029	—	3.6	4.7	5.4	6.0	6.6	9.3	12.0
WDA	WDB	8.0	.032	—	4.5	6.2	7.2	8.0	8.9	12.4	16.0
WDA	WDB	10.0	.035	4.8	5.6	7.7	8.9	10.0	11.0	15.5	20.0
WDA	WDB	12.0	.040	5.8	6.8	9.3	10.7	12.0	13.2	18.6	24.0
WDA	WDB	14.0	.040	6.8	7.9	10.8	12.5	14.0	15.3	21.7	28.0
WDA	WDB	16.0	.046	7.8	9.0	12.4	14.3	16.0	17.5	24.8	32.0
WDA	WDB	18.0	.052	8.8	10.1	13.9	16.1	18.0	19.7	27.9	36.0
WDA	WDB	20.0	.055	9.8	11.3	15.5	17.9	20.0	21.9	31.0	40.0
WDA	WDB	24.0	.060	12.3	13.5	18.6	21.5	24.0	26.3	37.2	48.0
WDA	WDB	30.0	.067	14.6	16.9	23.2	26.8	30.0	32.9	46.5	60.0
WDA	WDB	35.0	.070	17.2	19.8	27.2	31.4	35.0	38.4	54.3	70.0

*NOT AVAILABLE IN 30"

WDA-WDB Nozzles above 16.0 GPH are furnished without strainers.

Max. Design Pressure: 500 psig